

**ANNULUS CLOSURE
TECHNOLOGY DEVELOPMENT
INSPECTION / SALT DEPOSIT CLEANING
MAGNETIC WALL CRAWLER**

R. L. Minichan
R. E. Eibling
J. B. Elder
K. E. Kane
D. Kremenz
R. W. Vandekamp
N. J. Vrettos

June 2008

Robotics, Remote & Specialty Equipment Section
Engineered Equipment and Systems Directorate
Savannah River National Laboratory
Aiken, SC 29808

Prepared for the U.S. Department of Energy Under Contract Number
DE-AC09-96SR18500



SRNL
SAVANNAH RIVER NATIONAL LABORATORY

DISCLAIMER

This report was prepared by Washington Savannah River Company (WSRC) for the United States Department of Energy under Contract No. DE-AC09-96SR18500 and is an account of work performed under that contract. Neither the United States Department of Energy, nor WSRC, nor any of their employees makes any warranty, expressed or implied, or assumes any legal liability or responsibility for the accuracy, completeness, or usefulness, of any information, apparatus, or product or process disclosed herein or represents that its use will not infringe privately owned rights. Reference herein to any specific commercial product, process, or service by trademark, name, manufacturer or otherwise does not necessarily constitute or imply endorsement, recommendation, or favoring of same by WSRC or by the United States Government or any agency thereof. The views and opinions of the authors expressed herein do not necessarily state or reflect those of the United States Government or any agency thereof.

Printed in the United States of America

**Prepared For
U.S. Department of Energy**

Key Words:

*Robotics,
Remote,
Equipment,
Magnetic,
Wall Crawler*

Retention:

Permanent

**ANNULUS CLOSURE
TECHNOLOGY DEVELOPMENT
INSPECTION / SALT DEPOSIT CLEANING
MAGNETIC WALL CRAWLER**

R. L. Minichan
R. E. Eibling
J. B. Elder
K. E. Kane
D. Krementz
R. W. Vandekamp
N. J. Vrettos

June 2008

This page intentionally left blank.

This page intentionally left blank.

EXECUTIVE SUMMARY

The Liquid Waste Technology Development organization is investigating technologies to support closure of radioactive waste tanks at the Savannah River Site (SRS). Tank closure includes removal of the wastes that have propagated to the tank annulus. Although amounts and types of residual waste materials in the annuli of SRS tanks vary, simple salt deposits are predominant on tanks with known leak sites. This task focused on developing and demonstrating a technology to inspect and spot clean salt deposits from the outer primary tank wall located in the annulus of an SRS Type I tank.

The Robotics, Remote and Specialty Equipment (RRSE) and Materials Science and Technology (MS&T) Sections of the Savannah River National Laboratory (SRNL) collaborated to modify and equip a Force Institute magnetic wall crawler with the tools necessary to demonstrate the inspection and spot cleaning in a mock-up of a Type I tank annulus. A remote control camera arm and cleaning head were developed, fabricated and mounted on the crawler. The crawler was then tested and demonstrated on a salt simulant also developed in this task. The demonstration showed that the camera is capable of being deployed in all specified locations and provided the views needed for the planned inspection. It also showed that the salt simulant readily dissolves with water. The crawler features two different techniques for delivering water to dissolve the salt deposits. Both water spray nozzles were able to dissolve the simulated salt, one is more controllable and the other delivers a larger water volume. The cleaning head also includes a rotary brush to mechanically remove the simulated salt nodules in the event insoluble material is encountered. The rotary brush proved to be effective in removing the salt nodules, although some fine tuning may be required to achieve the best results.

This report describes the design process for developing technology to add features to a commercial wall crawler and the results of the demonstration testing performed on the integrated system. The crawler was modified to address the two primary objectives of the task (inspection and spot cleaning).

SRNL recommends this technology as a viable option for annulus inspection and salt removal in tanks with minimal salt deposits (such as Tanks 5 and 6.) This report further recommends that the technology be prepared for field deployment by;

- (1) developing an improved mounting system for the magnetic idler wheel,
- (2) improving the robustness of the cleaning tool mounting,
- (3) resolving the nozzle selection valve connections,
- (4) determining alternatives for the brush and bristle assembly,
- (5) adding a protective housing around the motors to shield them from water splash.

In addition, SRNL suggests further technology development to address annulus cleaning issues that are apparent on other tanks that will also require salt removal in the future such as:

- (1) Developing a duct drilling device to facilitate dissolving salt inside ventilation ducts and draining the solution out the bottom of the ducts.
- (2) Investigating technologies to inspect inside the vertical annulus ventilation duct.

This page intentionally left blank.

TABLE OF CONTENTS

EXECUTIVE SUMMARY	viii
LIST OF FIGURES	xii
LIST OF TABLES	xii
LIST OF ACRONYMS	xiii
1.0 INTRODUCTION AND BACKGROUND.....	1
2.0 APPROACH.....	3
2.1 Waste Tank Mockup Annulus Modification	3
2.2 Wall Crawler Platform Development	4
2.3 Camera Arm Development.....	5
2.4 Cleaning Tool Development.....	6
2.5 Crawler Control System	8
2.6 Salt Simulant	8
2.7 Technology Demonstration	11
3.0 Results.....	11
3.1 Wall Crawler Demonstration Summary	12
3.1.1 Crawler/Platform Performance	12
3.1.2 Ventilation Duct Inspection Performance	12
3.1.3 Consequence of Component Failure	12
3.1.4 Salt Nodule Removal Performance	13
4.0 Conclusions.....	13
5.0 Recommendations/path Forward	13
6.0 References.....	14
7.0 Acknowledgements.....	14
APPENDIX A. Demonstration Plan Evaluation Criteria and Summary	15
APPENDIX B. Salt Simulant Recipe	20
Distribution:	21

This page intentionally left blank.

LIST OF FIGURES

Figure 2-1 723-A Annulus Mockup Modification3
Figure 2-2 Annulus Inspection / Cleaning Wall Crawler.....4
Figure 2-3 Camera Arm Assembly5
Figure 2-4 Brush & Nozzle Assembly6
Figure 2-5 Modified Wall Crawler on Tank Mockup Wall7
Figure 2-6 External Control Box8
Figure 2-7 Typical Salt Deposit Produced on a Vertical Plate10
Figure 2-8 Typical Salt Deposit Produced on an Inclined Plate 10

LIST OF TABLES

Table 2-1 Simulant for Producing Salt Deposits9

LIST OF ACRONYMS

GPM – gallon per minute

LWO – Liquid Waste Operations

MS&T – Materials Science and Technology

PTZ – pan tilt zoom

RRSE – Robotics, Remote and Specialty Equipment

SRNL – Savannah River National Lab

SRS – Savannah River Site

WCS – Waste Characterization System

1.0 INTRODUCTION AND BACKGROUND

Most Savannah River Site (SRS) waste tanks include a secondary containment feature that results in an annulus space around the primary tank. There are a few tanks with previous leak sites that have resulted in material entering the annulus space and forming salt deposits in that location. These leak sites are well documented and are closely monitored. The tank levels are normally dropped below the elevation of the leak sites to minimize the chance of any additional material entering the annulus. One of the initiatives of Liquid Waste Operations (LWO) is to work toward closing tanks in that condition. One of the major steps in closing these tanks is removing the waste including any salt deposits in the annulus. This report documents the development process to modify an existing wall crawler and the results of the demonstration testing performed on the latest wall crawler. The crawler was upgraded to address the two primary objectives of the task (inspection and spot cleaning).

The objective of this task was to develop and demonstrate technology capable of annulus space inspection and salt deposit removal. The scope of this task is documented in the Task Technical Request¹ and includes the following:

1. Adding annulus features to the waste tank mockup in 723-A. This included adding an outer annulus wall and ventilation duct in the bottom.
2. Developing a salt simulant to represent the salt expected to be found in a waste tank annulus for testing salt removal techniques.
3. Developing and building prototype equipment to demonstrate the technical capability of inspecting the annulus space (including inside and under the ventilation duct) and removing salt from the tank wall.
4. Performing tests to verify the technologies developed in this task are capable of performing the intended tasks.

This page intentionally left blank.

2.0 APPROACH

In order to accomplish the objectives described earlier, the waste tank mockup was upgraded, a commercial magnetic wall crawler was modified and a salt simulant was developed. Each of these components of the task were integrated together in the demonstration testing to show the capabilities of the annulus closure technologies developed in this task.

2.1 Waste Tank Mockup Annulus Modification

There was an existing waste tank wall mockup in the high bay of 723-A, however, it did not include a mockup of the annulus space. The tank mockup wall provides a similar wall thickness to that of Type I tanks. Although the waste tank mockup was built straight to simplify construction it is believed to be a fair representation due to the large radius of the actual tanks. In order to test and demonstrate the inspection/cleaning capabilities of the equipment developed for this task, the mockup was modified to include the outer pan wall and floor of the annulus space. In addition, a section of the annulus ventilation duct was added. The duct includes one flange and opening in order to test the duct inspection capability. The duct is modular so that it can be added to or removed from the mockup depending upon the mockup needs. The duct diameter varies around the waste tank circumference so sections representing the large and small diameters were built. Adding these features was necessary to fully demonstrate the new capabilities being added to the wall crawler. The tank mockup will be maintained as a tool for future equipment development and testing. A diagram of the tank wall mockup can be seen in Figure 2-1.

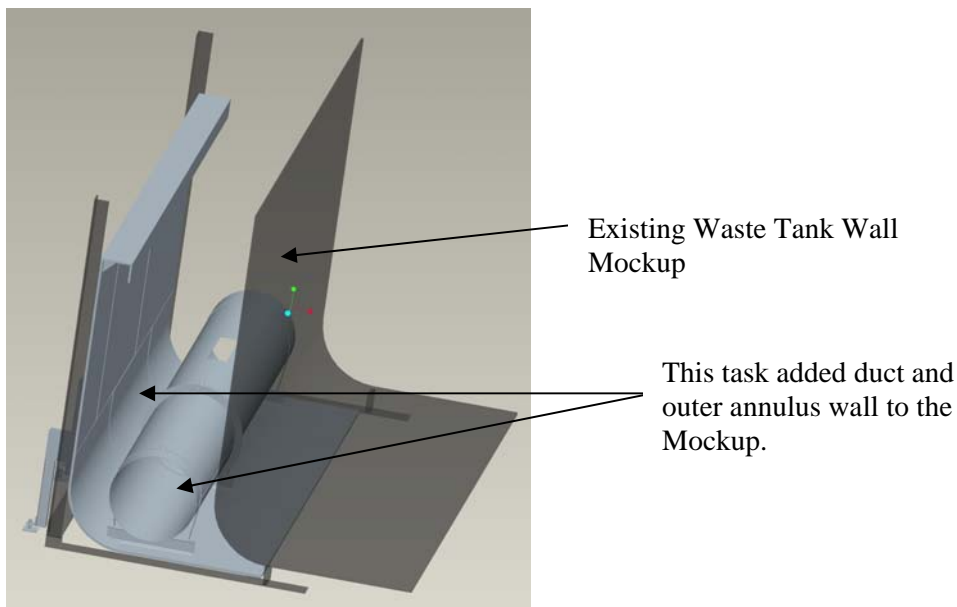

Figure 2-1 723-A Annulus Mockup Modification

2.2 Wall Crawler Platform Development

The Annulus Inspection/Cleaning Magnetic Wall Crawler was developed to expand the technology currently used for inspection and add features to remove salt deposits from the Outer Diameter (OD) of the primary tank wall. The Force Institute magnetic wall crawler has been successfully used by MS&T to visually inspect and perform Ultrasonic Testing (UT) thickness measurements in the annulus of SRS waste tanks for many years. Since the Force Institute magnetic Wall crawler has been successfully deployed in the target locations it was chosen as the platform to deliver the new tools capable of inspecting and cleaning the annulus of tanks with salt deposits from leak sites. Other platform options were considered. Some preliminary development was even done on an idea for a new magnetic wall crawler that would potentially be smaller and more maneuverable. However, the uncertainty of a new development project along with operator and facility confidence in a proven platform pointed toward using the Force Institute Wall Crawler as the platform for the new capabilities.

The Force Institute crawler includes two sets of magnetic wheels, one at each end of the crawler. The wheels are very strong magnets that hold the crawler to a magnetic metal wall. Each magnetic wheel has a holding force of approximately fifty pounds. The wheels can be controlled independently to steer the crawler. The crawler travels in a direction perpendicular to its length. The crawler also comes with a movable carriage that is located between the wheels that is typically used to position UT probes. The crawler is operated by a computerized controller. In order to achieve the additional objectives of this task, a camera arm system and a brush & nozzle attachment were designed, built and added to a Force Institute Magnetic Wall Crawler which can be seen in Figure 2-2.

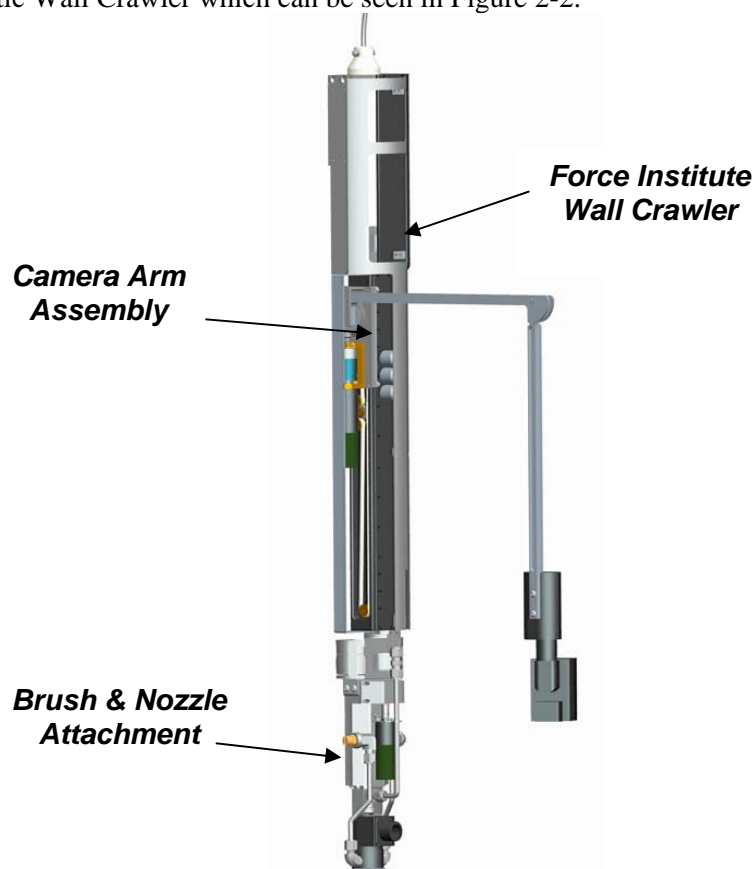

Figure 2-2 Annulus Inspection / Cleaning Wall Crawler

2.3 Camera Arm Development

Duct inspection was achieved by replacing the UT scanning equipment on the Force Institute crawler with a pan/tilt/zoom camera on an arm. The arm allows the camera to get the necessary distance away from the annulus wall so that it can enter the duct opening. A DC motor with a high gear ratio is used with a bevel gear arrangement to lift the arm. A slip-clutch positioned between the motor and one of the bevel gears protects the motor when driven at the extremes of the arm's range. To lower the camera into the duct opening the belt mechanism built into the wall crawler for UT scanning is used. This allows the entire camera arm assembly to be lowered approximately nine inches. A small nozzle placed on the camera (not shown in Fig 2-3) provides the ability for the crawler to aim & direct a small stream of water approximately four feet in any direction to aid cleaning efforts.

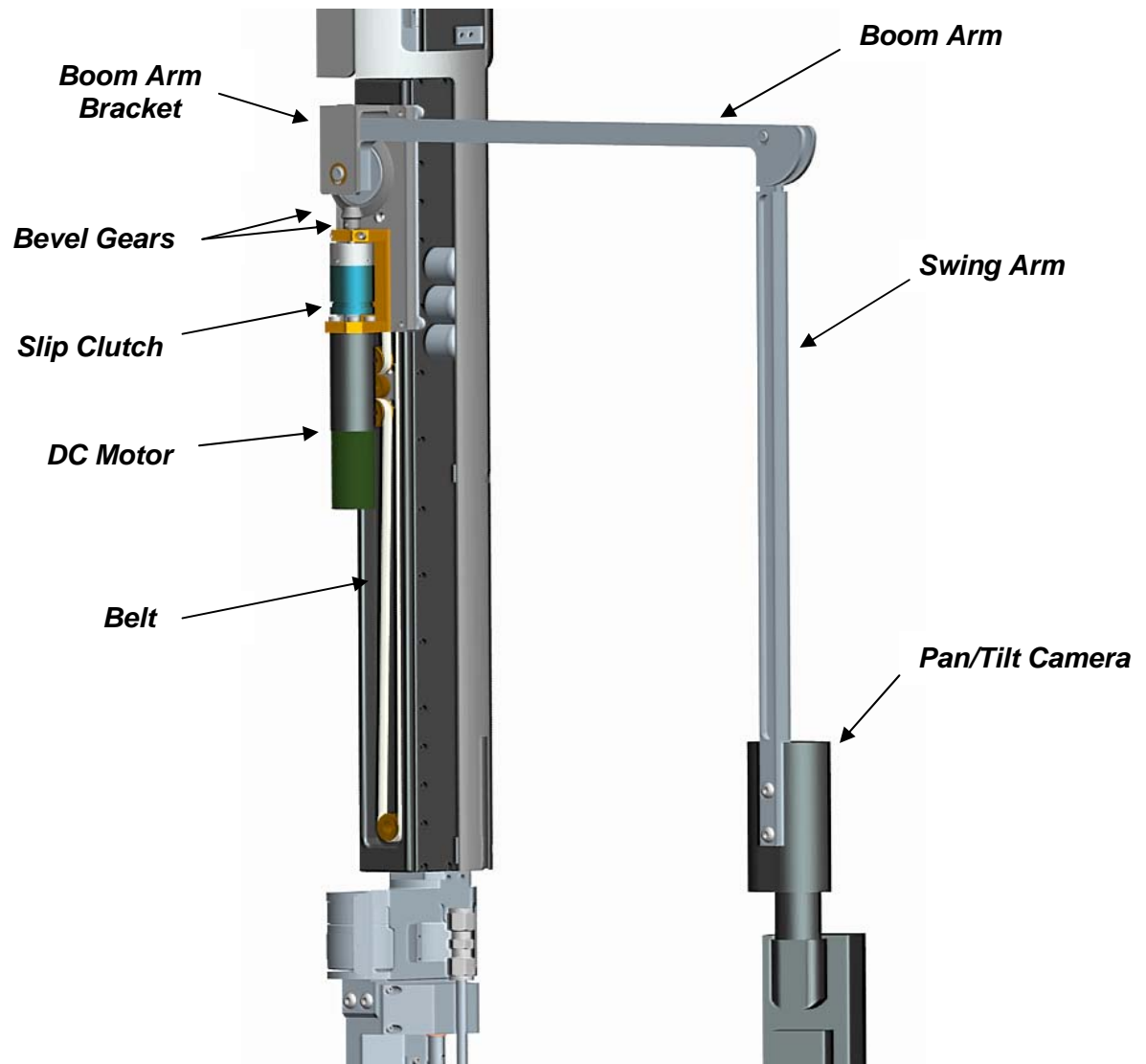

Figure 2-3 Camera Arm Assembly

2.4 Cleaning Tool Development

The main function of the brush and nozzle is to relocate any salt deposits from the annulus wall to the floor. The salt will be removed either by dissolution using spray nozzles or mechanically using a rotary brush. Once the material is on the floor LWO will add a few inches of water to the annulus to dissolve any remaining salt and pump it out for disposition. Previous experience indicates that the salt readily dissolves in water. Testing the salt simulant confirmed that it dissolves well when in contact with water. Therefore, water nozzles are one of the main tools planned for removing salt from the annulus wall. The primary cleaning equipment on the crawler is the brush and nozzle attachment that is situated below the bottom magnetic drive wheels. Two nozzles are placed on the attachment one facing forward and one backwards to allow high pressure (~80-90 psi) washing of the annulus wall surface. The water is fed to the nozzles through a solenoid valve that allows switching between the nozzles. The brush provides a mechanical means of removing salt from the annulus surface in the event an insoluble or difficult to remove salt nodule is encountered. The system uses a brush coupled to a DC motor with a sprocket and chain mechanism in order to spin the rotating brush. The brush has nylon bristles that are impregnated with abrasive material. The device is designed such that there is a clearance between the brush and the tank surface so the brush will only act on foreign deposits.

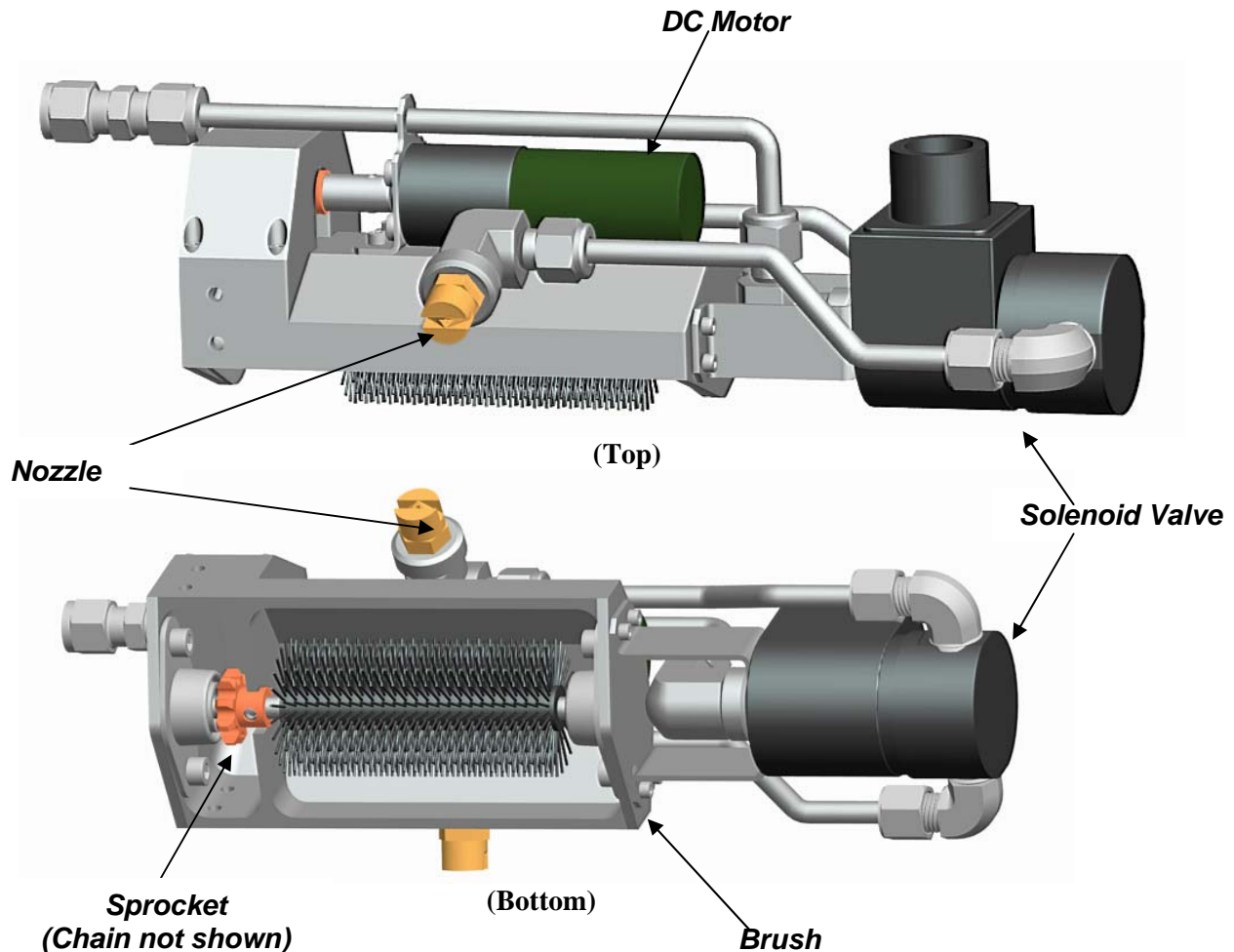

Figure 2-4 Brush & Nozzle Assembly

If the brush is used to remove salt from the annulus wall there could be residual salt particles remaining on the brush or shield that need cleaned prior to extracting the crawler from the annulus. The brush can be cleaned by operating the brush while spraying water on the wall directly above the rotating brush. The brush end of the crawler could also be sprayed with a separate wand below the riser as part of the wall crawler removal process.

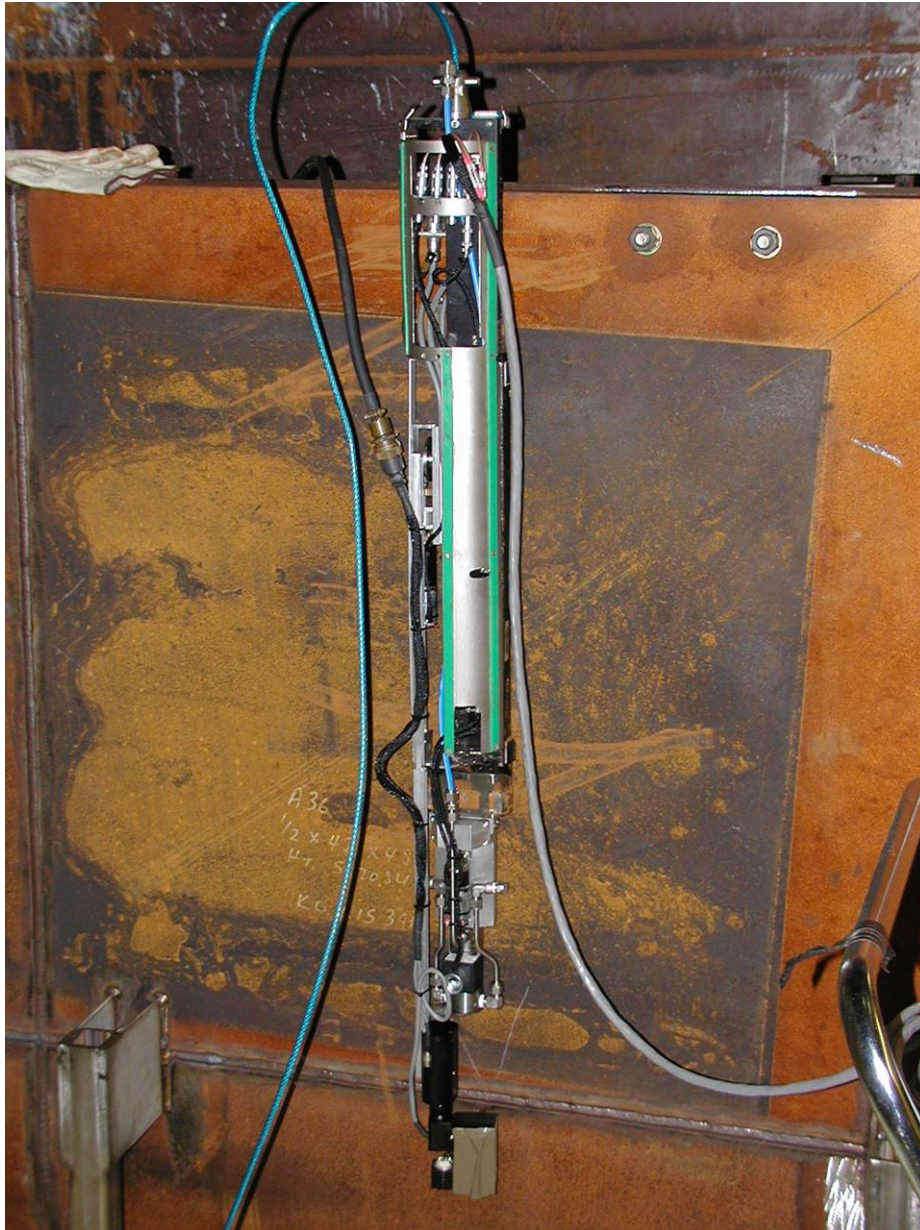

Figure 2-5 Modified Wall Crawler on Tank Mockup Wall

2.5 Crawler Control System

The Force Institute Wall Crawler is manipulated by its own computer based control system. The existing control system is used to operate the original functions of the wall crawler. The new features that were added are controlled by a separate self contained control box. This strategy kept the control system development simple and leaves the wall crawler control intact so it can continue to be used with unmodified crawlers. The camera arm assembly is raised and lowered by a motor axis built into the commercial crawler and normally used for positioning UT probes.

The new control box provides the ability to raise and lower the camera arm by rotating it 90°, turn the brush motor on and off and select the nozzle for spraying the salt nodules. The electrical design uses a simple set of toggle switches to provide either 12 or 24 VDC to the onboard robotics tools. All functions are labeled on the panel of the electronics enclosure, which is designed to be splash proof. The external power supply requirement is a standard 120 VAC plug. Additional 100ft cable extensions (with 1/4 turn quick release bayonet connectors) allow the user(s) to increase the distance up to a few hundred feet as required for remote deployment.



Figure 2-6 External Control Box

2.6 Salt Simulant

The supernate simulant for production of waste tank annulus salt deposits was based upon a composition that represents the major species present in Tanks 5 F and 6 F. The ionic composition was initially proposed by Liquid Waste Operations Engineering based upon a review of the range of supernate compositions reported in the Waste Characterization System (WCS) for these tanks.² The proposed composition at 3.6 molar in Na was converted to a compound basis and is shown in Table 2-1. The

proposed composition would require a substantial amount of water to evaporate before salt deposition would begin. Therefore, a range of compositions were prepared to determine the highest concentration that would require the least amount of evaporation to initiate salts deposition. The chosen composition is shown in the final column of the table and has a total sodium concentration of 9.0 molar and a density of 1.37 grams/milliliter.

Table 2-1 Simulant for Producing Salt Deposits

Compound	Initially Recommended Concentration, moles/L ⁽²⁾	Simulant Composition Used, moles/L
Sodium Hydroxide	1.00	2.50
Sodium Nitrate	1.00	2.50
Sodium Nitrite	0.50	1.25
Sodium Carbonate	0.50	1.25
Sodium Aluminate	0.10	0.25
Density, g/mL	1.17	1.37

The salt deposits were produced using carbon steel plates mounted in two different positions. The least massive deposits were produced by mounting the steel plates vertically and allowing the salt solution to weep through a horizontal seam on the upper portion of the plate. The plate was heated by hot air blowers to accelerate evaporation. Deposition by this process was slow since liquid drained off the plate before all of the water had evaporated. The second position for the carbon steel plate was a slightly inclined position (10-15 degrees) and the supernate was added slowly near the top of the plate. The steel sheet was heated by large heating pads mounted on the reverse of the plate with a controlling thermocouple mounted between the pad and the steel plate. The heated pad was maintained at 90° C while the air flow in the chemical hood carried the evaporated water away from the deposits. This approach deposited much larger quantities of solids.

The salt deposits produced on the vertical plates were probably mostly sodium carbonate with some aluminum hydroxide. The aluminum hydroxide would be generated by the reaction between carbon dioxide in the air and sodium aluminate in the liquid as shown below.



The more massive deposits are more likely to contain not only sodium carbonate and aluminum hydroxide but also more of the other salts due to the greater degree of evaporation achieved with the low angle plate position. The other salts include sodium nitrate, sodium nitrite and possibly sodium aluminate. Sodium hydroxide is another salt that may be present although less likely.



Figure 2-7 Typical Salt Deposit Produced on a Vertical Plate



Figure 2-8 Typical Salt Deposit Produced on an Inclined Plate

2.7 Technology Demonstration

New features developed for the wall crawler in this task are described in previous sections, however, in order to determine the effectiveness of these modifications the functions required testing in realistic conditions. The additions to the tank wall mockup in 723-A created an annulus space to demonstrate the crawler in action. Salt simulant deposited on a test plate mounted in the mockup provided a sample for checking the effectiveness of the new cleaning features on the wall crawler. A demonstration plan³ was developed and approved so the testing could proceed in a methodical fashion checking all the features and capabilities of interest to the development team and customer. The results of the demonstration testing are described in the next section.

3.0 RESULTS

This task resulted in technology being developed that will support SRS Waste Tank annulus cleaning including:

- A. The 723-A waste tank mockup was upgraded to include the annulus space. A modular ventilation duct that can be installed or removed depending on the requirements was added. The ventilation duct includes flanges and duct openings to help test annulus devices. The mockup was used for this task and will be available for future development work and testing.
- B. A simulant was developed with the same physical and chemical characteristics of the actual salt. This includes its chemistry and response to water and physical contact in comparison to previous field experience. The simulant was used to test the effectiveness of the salt removal tools developed in this task.
- C. Devices to modify the Force Institute wall Crawler for inspecting the annulus space were developed. A camera deployment arm was developed that helps position a camera for annulus inspection, i.e. general area, inside ventilation duct and under the ventilation duct.
- D. Salt cleaning devices to add to the Force Institute wall Crawler for removing salt from the tank wall were developed. These include a small water nozzle on the Pan Tilt Zoom (PTZ) camera that can be aimed at salt deposits. In addition, an attachment that mounts to the end of the crawler which includes a pair of water nozzles and a power brush for mechanical cleaning was designed. The nozzles can be selected one at a time and deliver about 1 gpm of water to the target. These nozzles can only be aimed by positioning the entire crawler. The rotary brush must also be positioned with the crawler and can be used for difficult salt deposits or areas that do not readily dissolve.
- E. Lastly the waste tank annulus mockup was used to demonstrate the capabilities of the prototype modified wall crawler. The tests described in the demonstration plan showed that the technology developed in this task is able to perform the intended tasks. It should be noted that the unit built for this task is a prototype and will require some effort to place the system in a field deployable condition. Notes and observations from the demonstration testing are in section 3.1. Also, the actual data sheets from the demonstration testing are included as Attachment A.

3.1 Wall Crawler Demonstration Summary

The Wall Crawler Demonstration Plan³ was executed to test the features and functionality of the wall crawler. The Demonstration Plan details the criteria for the tests and the results are summarized in the following sections. The actual data sheets from the Demonstration Plan testing are located in Appendix A.

3.1.1 Crawler/Platform Performance

Deployment: The crawler can be deployed through a five inch riser, however, the additional components add to the difficulty of deployment. There is a risk that the crawler could become damaged during deployment. The attachment method for the cleaning tool is one area of vulnerability. It was determined during the demonstration testing that a more substantial bracket should be developed and used to secure the cleaning tool directly to a structural part of the magnetic wall crawler.

Maneuverability: The crawler maneuvers well from point to point. The added length of the unit means additional space is needed to navigate the crawler on the tank wall. The modifications to the wall crawler added weight to the stock system. An additional, magnetic wheel (idler) was added to the crawler to help support the extra weight. The idler wheel was tested during the deployment demonstration. A more permanent bracket should be developed to support the idler wheel prior to use in the field.

Boom Arm Operation: The crawler can be driven circumferentially with the boom arm extended. The boom arm can be remotely deployed and stowed. The crawler must be in a vertical position to stow the camera boom arm which can be a delicate process. The camera boom arm must be stowed properly to remove the crawler from the annulus through a riser. Additional camera views might be helpful while extracting the crawler from the annulus.

Brush Attachment: The bristles on the brush that was tested on the crawler are fairly stiff and may not be the ideal choice for this application. When driving the brush over obstacles the brush has the potential to lift the crawler off the wall, also the motor doesn't have enough torque to turn the brush when in direct contact with the wall. A modification is recommended prior to field deployment. It is suggested that a brush with longer and/or softer bristles be considered. The current motor can then be reevaluated.

3.1.2 Ventilation Duct Inspection Performance

The crawler was able to position the camera over the duct opening. The camera boom arm operated properly and was able to reach inside both the smaller diameter and the larger diameter duct and perform a visual examination. The picture was very high quality and the camera can see down the duct until the radius turns.

3.1.3 Consequence of Component Failure

Crawler Movement: Loss of a single X motor, loss of control or complete crawler failure are potential issues that could result in a minor or significant recovery effort depending on where the crawler is located. Worst case might be if the crawler is positioned between the ventilation duct and the primary wall to perform a floor or an internal duct inspection where the crawler needs both X motors to maneuver to get back to a safe place for retrieval. The crawler would have to be drug out and could get stuck during retrieval. A malfunction of the pneumatic cylinders that separate the magnetic wheels from the tank wall for crawler recovery will be a more straight forward recovery process. A way to decouple the crawler's magnetic wheels from the wall would simply need to be developed.

Y-drive belt breakage could result in damage to the camera boom arm during retrieval. It would probably be possible to retrieve the equipment but something could be damaged during the removal process. Loss of lights, PTZ function and picture are all issues that would make it necessary to pull the crawler for repairs but probably could be dealt with by placing additional cameras in different risers.

3.1.4 Salt Nodule Removal Performance

The camera mounted spray nozzle performed very well in hitting targets on the primary wall, primary knuckle, secondary wall and the dehumidification duct and dissolving the salt nodule due to the ability to aim the water stream. Water was supplied to the camera mounted spray nozzle with a small peristaltic pump. The spray nozzles mounted on the cleaning attachment were effective at dissolving the salt and delivered a larger volume of water which was supplied through a hose connected to process water. The limitation of these nozzles is that they can only be positioned by moving the entire crawler. The nozzles on the cleaning attachment are used one at a time as directed through a solenoid valve. Unfortunately, the solenoid valve did not function properly during the tests. This issue can be solved by swapping two of the connections. Testing showed the simulated salt readily dissolved and separated from the tank wall with the application of water. The rotary brush was also tested on a simulated salt nodule and it appeared that mechanical cleaning and physically impacting the salt nodules are also effective at removing the salt from the tank wall. During the brush test it appeared that after some contact the entire salt nodule simply broke off the wall and fell to the bottom of the annulus indicating that the bond to the tank wall may not be very strong.

4.0 CONCLUSIONS

The technology and operational techniques developed for this task resulted in a number of tools that can be effectively used to inspect and remove salt from the walls of waste tank annuli. These tools will be ideal for use on waste tanks that have small amounts of salt in the annulus space such as tanks 5 and 6. Further development may be necessary to deal with tanks that have large amounts of salt in the annulus space in a reasonable time period. The devices built in this task and used in the demonstration on the wall crawler are prototypes and were not intended for direct field deployment. Some additional effort will be required to prepare the crawler and tools for use in the field.

5.0 RECOMMENDATIONS/PATH FORWARD

The modifications that were added to the Force Institute wall crawler have proven effective and can be recommended for annulus inspection and salt removal especially in tanks with minimal salt deposits. The modified wall crawler is ideal for annulus closure in tanks such as 5 and 6 which are the tanks targeted for closure in the near term. The wall crawler system built for this task is a prototype and will require some attention to place it in a field ready condition. Some of the items that should be considered to prepare the upgraded crawler for field deployment include:

- Develop an improved mounting system for the magnetic idler wheel.
- Add a mounting plate for the water nozzle / brush cleaning sub-assembly that allows this unit to be secured to a more structural part of the magnetic wall crawler.
- The nozzle selection valve operation should be resolved.
- Investigate alternate brushes for the rotary brush that may include longer more flexible bristles.
- Add protective housing around the motors to shield them from water splash.

- Perform a review on the entire crawler system to look for ways to make the unit more robust, ease maintenance (modular), protect wiring from water, etc.

Spare Wall Crawler/Spare parts – Wall crawlers are complex custom built devices which are likely to require attention during use. If custom machined parts or long lead parts are damaged during use it could take an extended time period to repair the crawler. For these reasons, and the effort required to plan a deployment of this type, it is recommended that building an entire spare crawler or at a minimum fabricating/purchasing key spare parts be considered.

Duct Drilling Device – In planning for future tank closures, it may become necessary to flood the entire annulus with several feet of water to remove bulk salt from the annulus or ventilation duct internals. SRNL has built and deployed a duct drilling device for drilling through the top of the duct to take salt samples. This design can easily be adapted to a unit capable of drilling through the duct bottom. A duct with holes in the bottom will allow any saturated solution that enters the duct during salt removal to drain out of the ventilation duct. This capability will help ensure salt is removed from the annulus to the maximum extent practical in tanks with excess salt deposits in the annulus. Therefore, it is recommended that LWO have a duct drilling device built to help with annulus cleaning situations as described above.

6.0 REFERENCES

- ¹ Adkins, B. J. *Task Technical Request, Provide Annulus Closure Technology Development Support*. HLE-TTR-2007-023, Savannah River Site, Aiken SC 29808 (May 17, 2007)
- ² Adkins, B. J. *Requested Salt Simulant Recipe*. Email, Savannah River Site, Aiken SC 29808 (July 23, 2007) [see attachment B]
- ³ Elder, J. B. *Wall Crawler Demonstration Plan for Waste Removal Operations in Type I / II Waste Tank Annuli*. SRNL-MST-2008-00008, Savannah River Site, Aiken, SC 29808 (2008).
- ⁴ Minichan, R. L. *Hazard Assessment Package, Annulus Cleaning Magnetic Crawler Assembly and Testing*. SRNL-RSE-2007-00092, Savannah River Site, Aiken, SC 29808 (2007).
- ⁵ Minichan, R. L. *Task Technical / QA Plan Annulus Closure Technology Annulus Closure Technology Development Support*. WSRC-RP-2007-01254, Savannah River Site, Aiken, SC 29808 (2007).

7.0 ACKNOWLEDGEMENTS

A note of appreciation is in order for all those who contributed to the success of this task including Brannen Adkins (Liquid Waste customer), Jim Buchanan with procurement support, Nate Miller with material logistics, Micah Boylston, Tommy McCoy & Mike Stowell with shop fabrication, and Frances Williams et al. with salt simulant preparation.

APPENDIX A. Demonstration Plan Evaluation Criteria and Summary

January 16, 2008

SRNL-MST-2008-00008
Page 5 of 9

Appendix I Evaluation Criteria and Summary

Item	Criteria	Performance	Acceptable	Comment
Simulant Criteria				
Solubility	Easily dissolved by slow stream of water.	Simulant was dissolved and removed from tank wall	Yes	
Stability	Maintain shape and bind together		Yes	
Adhesion	Adheres to plate		Yes	
Crawler / Platform Criteria				
Deployment	Ability to pass in and out of 5" riser	Difficult / damage to the crawler is possible.	Yes	
Maneuverability	Ability to drive to given points, miss obstructions and traverse weld seams	The crawler maneuvers well, the added length requires a larger area to drive	Yes	
Boom arm operation	Arm remotely deployed and stowed. Able to maneuver crawler circumferentially	The arm does deploy and stow, not much room for error. And can be driven circumferentially	Yes	
Brush attachment	Crawler able to maneuver with brush attached and operating?	When driving over obstacles the scanner is lifted off the wall, And the brush does not work while in direct contact	No	Bracket needs to be fabricated so the weight and stress of the brush attachment is on the crawler frame instead of on the drive axle, also a brush with longer softer bristles needs to replace current brush so crawler will not be knocked off the tank wall during exam.
Wall separation force	Use dynamometer top measure load to separation or at least 200 lbs.	Four Standard Wheels (161 lbs) With 5 th wheel (241 lbs)	Yes	
Horizontal pull capacity	Use dynamometer to measure load to software overload.	40 lbs	Yes	

January 16, 2008

SRNL-MST-2008-00008
Page 6 of 9

Item	Criteria	Performance	Acceptable	Comment
Duct Internal Inspection Criteria	Demonstrate operability and inspection capability	Deployment acceptable, Picture quality excellent	Yes	
Alignment	Crawler able to position camera over duct opening	Crawler was positioned, extensive maneuvering required	Yes	Extensive maneuvering due to limited travel of camera boom arm
	Deployment of camera boom arm / alignment over duct openings in various sizes of duct	Crawler aligned and boom arm deployed in both duct sizes	Yes	
	Lower camera into duct	Camera was lowered into duct	Yes	
Inspection coverage	Picture quality	Picture was very high quality	Yes	
	Determine maximum coverage (ft. each direction)	Camera view limited by duct radius only (10' each direction)	Yes	
Consequence of component failure				
Crawler movement	Loss of single x motor or drive belt	Loss of control, might have to drag crawler out/could get stuck	Yes	
	Loss of control /complete failure	Same as above	Yes	
	Pneumatic de-couple jack failure	Could knock off the wall	Yes	
Y-drive belt	Belt breakage in Near position	Likely damage to boom arm and motor	Yes	Install rubber bumper on end of motor
	Damage to boom arm / operability		Yes	
	Determine impact on retrieval of camera from duct	Likely damage to boom arm and motor	Yes	

January 16, 2008

SRNL-MST-2008-00008

Page 7 of 9

Item	Criteria	Performance	Acceptable	Comment
Motorized boom arm	Consequences of motor/clutch slippage in each position	Should fail in down position	Yes	Likely damage on removal (requires removal)
	Boom breakage/joint failure	Same as above	Yes	Requires removal
PTZ Camera	Loss of lights	Might need additional cameras	Yes	Requires removal
	Loss of PTZ function	Same as above	Yes	Requires removal
	Loss of picture	Same as above	Yes	Requires removal
Under Duct Inspection	Ability to view bottom of primary knuckle and secondary floor below duct	Crawler maneuvered to view primary knuckle, secondary floor below duct	Yes	
Salt nodule removal – primary wall				
Camera mounted spray hose				
Alignment	Ability to hit target on primary wall and primary knuckle	All targets were hit at a distance of 6-8'	Yes	
	Ability to hit targets on dehumidification duct	All targets were hit at a distance of 6-8'	Yes	
	Ability to hit targets on secondary pan	All targets were hit at a distance of 6-8'	Yes	
Efficiency	Evaluate ability to dissolve salt nodule	Salt nodule washed from wall	Yes	
	Evaluate contamination of crawler from overspray	Minimal due to distance from salt nodule	Yes	
	Evaluate pump driven compared to supplied water	Low volume pump worked	Yes	Supplied water not tested due to acceptable performance pump

January 16, 2008

SRNL-MST-2008-00008
Page 8 of 9

Item	Criteria	Performance	Acceptable	Comment
Brush attachment & spray nozzles				
Alignment	Evaluate ability to hit targets on primary wall and primary knuckle	Hits targets within 12" of scanner on primary wall, Water flow down wall cleans below crawler and on primary knuckle	Yes	Requires crawler maneuvering
	Determine optimum orientation of cleaning nozzles	Aimed at salt nodule	Yes	
	Determine cleaning performance as a function of inlet supply pressure	Higher pressure only speeds up the removal	Yes	
Efficiency	Evaluate ability to dissolve salt nodule	Acceptable	Yes	Cleans well
	Evaluate contamination of crawler from overspray	Probable	Yes	Minimized by placing crawler above salt nodule
Impregnated / Plain Nylon brush	Removal of salt nodule	Crawler must be maneuvered to place brush in contact with salt deposit. Brush effectively removed salt nodule. Physical contact with brush system eventually resulted in entire nodule being dislodged and falling to annulus floor.	Yes	Other brushes could be evaluated to improve performance, i.e. softer or longer bristles.
	Dust generation	Could be sprayed then brushed	Yes	
	Base metal or scale removal or polishing	Not likely	Yes	
	Spark generation	Not likely	Yes	
	Puncture hazard	Not Likely	Yes	
Stainless Steel Brush	Not evaluated	N/A	N/A	Not recommended

January 16, 2008

SRNL-MST-2008-00008
Page 9 of 9

Salt Nodule Removal -- Dehumidification Duct and Secondary Wall

Removal of salt nodules from the dehumidification duct and secondary wall is not required in the TTQAP, but will be evaluated for use during mock-up testing.

Item	Criteria	Performance	Acceptable	Comment
Camera mounted spray hose Alignment	Ability to hit targets on dehumidification duct	Able to hit targets within 6-8' on or in duct	Yes	
	Ability to hit targets on secondary pan	Able to hit targets within 6-8' in line of sight.	Yes	
Efficiency	Evaluate ability to dissolve salt nodule	Salt nodules washed off the tank wall	Yes	
	Evaluate contamination of crawler from overspray	Minimal due to distance from crawler	Yes	
Brush Attachment	Applicability to Dehumidification duct or secondary wall	Not applicable to duct or secondary wall	N/A	

Recommendations:

Approvals:

SRNL / MNDE&C:

SRNL / EES:

LWO Engineering:

FTF Operations:

Name: Richard S. Madick
Name: Richard S. Madick
Name: George Ahi / Randy Dols
Name: RD

Date: 6/12/08
Date: 06/12/08
Date: 06/12/08
Date: 6/12/08

APPENDIX B. Salt Simulant Recipe



Brannen Adkins/WSRC/Srs
07/23/2007 02:45 PM

To: Richard Minichan/SRNL/Srs@Srs
cc: Michael Hay/SRNL/Srs@Srs, Scott Reboul/WSRC/Srs@Srs
bcc:
Subject: Requested Salt Simulant Recipe

Rick,

I sat down with Scott Reboul this morning and we reviewed WCS for Tanks 5 & 6 in order to provide some guidance on developing a salt nodule simulant for the annulus crawler demo. Based on our review, we are providing the following proposal:

[OH⁻] ~ 1 M
[NO₃⁻] ~ 1 M
[NO₂⁻] ~ 0.5 M
[Al(OH)₄⁻] ~ 0.1 M
[CO₃²⁻] ~ 0.5 M
[Na⁺] ~ 3.6 M

Have you had a chance to talk with Mike Hay regarding the procedure and set-up for making the salt nodules to support the demo? If needed, we can sit down with you and Mike to discuss.

Thanks,

Brannen J. Adkins
Liquid Waste Operations Engineering
Washington Savannah River Company (WSRC)
(803) 208-0803 phone
(803) 208-8234 fax

DISTRIBUTION:

B. J. Adkins, 766-H
R. E. Eibling, 999-W
J. B. Elder, 730-A
A. P. Fellingner, 723-A
J. C. Griffin, 773-A
K. E. Kane, 723-A
D. Krementz, 723-A
M. J. Mahoney, 766-H
S. L. Marra, 773-A
J. G. Sonnenberg, 773-A
K. H. Subramanian, 773-A
R. W. Vandekamp, 730-A
N. J. Vrettos, 723-A
EES Job Folder 23165, 730-A