

**This document was prepared in conjunction with work accomplished under Contract No. DE-AC09-96SR18500 with the U.S. Department of Energy.**

**This work was prepared under an agreement with and funded by the U.S. Government. Neither the U. S. Government or its employees, nor any of its contractors, subcontractors or their employees, makes any express or implied: 1. warranty or assumes any legal liability for the accuracy, completeness, or for the use or results of such use of any information, product, or process disclosed; or 2. representation that such use or results of such use would not infringe privately owned rights; or 3. endorsement or recommendation of any specifically identified commercial product, process, or service. Any views and opinions of authors expressed in this work do not necessarily state or reflect those of the United States Government, or its contractors, or subcontractors.**

**Model of Diffusers / Permeators for Hydrogen Processing**

by

William D. Jacobs and Thong Hang  
Savannah River National Laboratory  
Aiken, SC 29808

A paper proposed for the poster session at the  
***8<sup>th</sup> International Conference on Tritium Science and Technology***  
Rochester, New York  
September 16 - 21, 2007

and for publication in *Fusion Science and Technology*

---

This paper was prepared in connection with work done under Contract No. DE-AC09 96SR18500 with the U. S. Department of Energy. By acceptance of this paper, the publisher and/or recipient acknowledges the U. S. Government's right to retain a nonexclusive, royalty-free license in and to any copyright covering this paper, along with the right to reproduce and to authorize others to reproduce all or part of the copyrighted paper.

# MODEL OF DIFFUSERS / PERMEATORS FOR HYDROGEN PROCESSING

William D. Jacobs and Thong Hang

Savannah River National Laboratory: 999-2W/PO Box A, Aiken, South Carolina, 29808  
[william.jacobs@srnl.doe.gov](mailto:william.jacobs@srnl.doe.gov) and [thong.hang@srnl.doe.gov](mailto:thong.hang@srnl.doe.gov)

*Palladium-silver (Pd-Ag) diffusers are mainstays of hydrogen processing. Diffusers separate hydrogen from inert species such as nitrogen, argon or helium. The tubing becomes permeable to hydrogen when heated to more than 250°C and a differential pressure is created across the membrane. The hydrogen diffuses better at higher temperatures. Experimental or experiential results have been the basis for determining or predicting a diffuser's performance. However, the process can be mathematically modeled, and comparison to experimental or other operating data can be utilized to improve the fit of the model. A reliable model-based diffuser system design is the goal which will have impacts on tritium and hydrogen processing.*

*A computer model has been developed to solve the differential equations for diffusion given the operating boundary conditions. The model was compared to operating data for a low pressure diffuser system. The modeling approach and the results are presented in this paper.*

## I. INTRODUCTION

Palladium (or palladium-silver) diffusers, also called “permeators”, have been employed in tritium processing operations for many years to remove hydrogen isotopes (i.e., protium, deuterium, and tritium) from inert gas streams. Several new proposed projects (e.g., the ITER project or the Tritium Facilities Modernization and Consolidation at the Savannah River Site) require operating conditions beyond the range of past experience. In most cases, elaborate and expensive testing would have to be conducted to verify the modified apparatus configuration achieves its functional design.

The objective of the current work was to develop a mathematical model that would reliably predict the performance of a palladium diffuser for hydrogen removal. The model involves the diffuser design geometry and the basic process parameters.

## II. MODEL DEVELOPMENT

### II.A Murav'ev Model for Hydrogen Permeators

Murav'ev<sup>1</sup> constructed a mathematical model to calculate and optimize gas flow rates in the hydrogen-permeable palladium alloy capillaries of permeators. Fig. 1 schematically shows the modeled membrane apparatus in which hydrogen is recovered from a gas mixture by hydrogen permeation through the membrane into capillary channel.

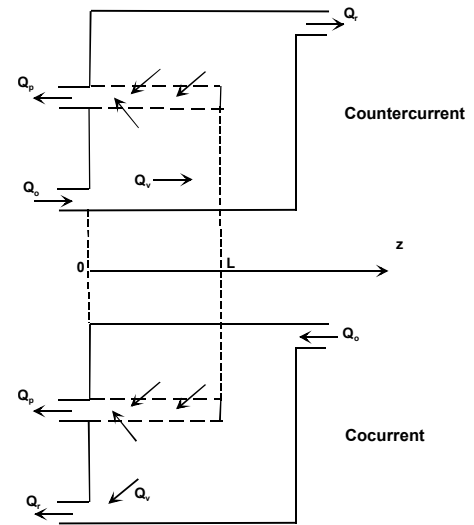

Fig. 1. Schematic of the membrane apparatus with the permeate flow inside the membrane tube

Since hydrogen flow in the capillaries is laminar with Reynolds number less 1000, the pressure drop across an elementary length can be described by the Hagen-Poiseuille equation:

$$dp = \frac{1}{d} \frac{r u^2}{2} dz \quad (1)$$

The rate of hydrogen flow through the membrane and the pressure drop across the membrane are related by the

Sieverts law:

$$dQ = \frac{g}{d} (p_v^r - p^r) dF \quad (2)$$

The exponent  $r$  accounts for the dissociation of the gas. For a non-dissociated gas,  $r = 1$ ; for a diatomic dissociating gas,  $r = 0.5$ . Experimental data indicated  $0.5 \leq r \leq 1$ .

Eqs. (1) and (2) can be rewritten in the dimensionless form:

$$\frac{dw}{dW} = m_v \frac{s}{w} \quad (3)$$

$$\frac{ds}{dW} = -m_s (X^r - bw^r) \quad (4)$$

where

$$m_v = \frac{128}{p} \frac{p_o}{T_o} mT \frac{L}{d^4} \frac{Q_o}{p_a^2} \quad (5)$$

$$m_s = \frac{pdLg p_{vo}^r}{dQ_o} \quad (6)$$

$$X = \frac{p_v}{p_{vo}} \quad (7)$$

$$b = \left( \frac{p_a}{p_{vo}} \right)^r \quad (8)$$

Murav'ev used the following dimensionless variables to derive Eqs. (3) and (4):

$$w = p/p_a \quad s = Q/Q_o \quad \omega = z/L \quad h = Q/Q_p$$

$$\alpha = Q_p/Q_o \quad v = Q_v/Q_o$$

Eqs. (3) and (4) are subjected to the boundary conditions

$$\omega = 0: \quad s = \alpha \quad w = 1 \quad (9)$$

$$\omega = 1: \quad s = 0 \quad \left( \frac{dw}{dW} = 0 \right) \quad (10)$$

The total material and hydrogen balance equations are provided for different flow directions.

For cocurrent flows:

$$v + s = 1 \quad X = \frac{X_v - s}{1 - s} \quad (11)$$

For countercurrent flows:

$$v - s = 1 - a \quad X = \frac{X_v - a + s}{1 - a + s} \quad (12)$$

Murav'ev proposed an algorithm to numerically solving the set of Eqs. (3) and (4). The model capabilities to predict the performance of high-temperature hydrogen permeators were demonstrated, in which the effects of the flow resistance of the capillaries, the flow directions, and the variation of the hydrogen concentration in the gas feed were accounted for. The model enables an optimal design of the capillary geometry and the process parameters.

## II.B ACM Software

The Aspen Custom Modeler™ (ACM) marketed by Aspen Technology, Inc. was selected as the modeling software in this work. The architecture of ACM makes it well suited to modeling and solving distributed parameters systems in which process variables vary with respect to spatial position as well as time described mathematically by partial differential equations (PDEs). ACM provides a number of built-in, well-known discretization methods that can be chosen for approximating partial derivatives and integrals. Complex ACM models have been successfully developed by researchers at the Savannah River National Laboratory (SRNL) in the past.<sup>2</sup>

Murav'ev model was coded in ACM. The calculated results presented in Ref. 1 were accurately reproduced. In all calculations performed in the current paper, the length domain  $L$  was divided into 20 elements. The 4<sup>th</sup>-order central finite difference was the selected discretization method. This computational scheme was found adequate to handle the problems of interest.

## II.C Modifications to Murav'ev Model

As shown in Fig. 1, the Murav'ev model was derived for hydrogen permeation through the membrane into the capillaries. Many hydrogen permeator systems in operation or being tested, however, have the reversed flow pattern. In those systems, the gas mixture flows in the membrane tubes, and hydrogen permeates through tubes into the shell side. A schematic of such membrane apparatuses is provided in Fig. 2.

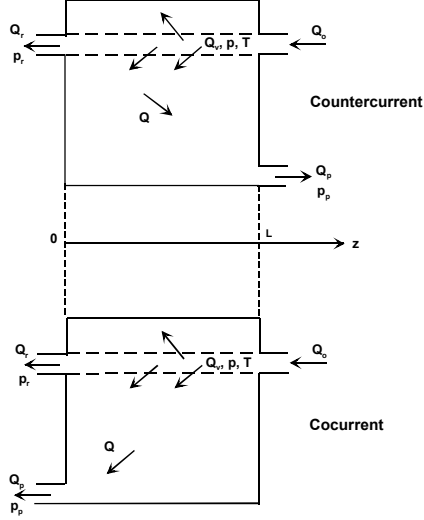

Fig. 2. Schematic of the membrane apparatus with the gas mixture flow inside the membrane tube

Murav'ev model was thus modified to appropriately describe these membrane configurations. All governing equations, dimensionless variables and the boundary conditions are summarized below.

$$\frac{dw}{dW} = m_v \frac{v}{w} \quad (13)$$

$$\frac{ds}{dW} = \mp m_s [w^r X^r - b] \quad (14)$$

- Cocurrent  
+ Countercurrent

where

$$m_v = \frac{128}{p} \frac{p_o}{T_o} mT \frac{L}{d^4} \frac{Q_o}{p_r^2} \quad (15)$$

$$m_s = \frac{pdLgpr^r}{dQ_o} \quad (16)$$

$$X = \frac{p_v}{p} \quad (17)$$

$$b = \left( \frac{p_p}{p_r} \right)^r \quad (18)$$

Dimensionless variables:

$$w = p/p_r \quad s = Q/Q_o \quad \omega = z/L \quad h = Q/Q_p$$

$$\alpha = Q_p/Q_o \quad v = Q_v/Q_o$$

Boundary conditions:

$$\omega = 0: \quad s = \begin{array}{l} \alpha \text{ (Cocurrent)} \\ 0 \text{ (Countercurrent)} \end{array} \quad (19)$$

$$w = 1$$

$$\omega = 1: \quad s = \begin{array}{l} 0 \text{ (Cocurrent)} \\ \alpha \text{ (Countercurrent)} \end{array} \quad (20)$$

$$X = X_v$$

The total material and hydrogen balance equations are the same as in Eqs. (11) and (12). Although having the gas feed in the tubes remarkably increases the Reynolds number of the tube flow, at the highest feed flow rates of interest the Reynolds number is less than 2000. Consequently, the Hagen-Poiseuille equation (Eq. 13) is still applicable.

### II.C.1 Effect of r

Calculations were performed with two selected values of r, 0.5 and 1. In each calculation, permeability  $\gamma$  was varied to achieve the best result in comparison to the data obtained from experimental testing of a low-pressure diffuser conducted at the Los Alamos National Laboratory (LANL). In these tests, hydrogen was removed from the feed, a mixture of nitrogen and hydrogen. The results in Fig. 3 confirm hydrogen permeation would be best modeled with  $r = 0.5$ . Note all flow rates are reduced to normal conditions (i.e.,  $p_o = 1.01325$  bar,  $T_o = 273$  K).

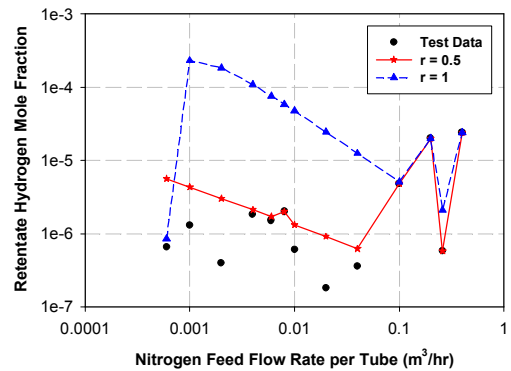

Fig.3. Effect of r on hydrogen permeation

### II.C.2 Permeability

The LANL testing indicated permeability correlates well with the tube-side flow rate, thus suggesting a substantial mass transfer resistance in the gas phase.

Generally, the tube-side flow rate should not affect the permeation rate in the palladium or the mechanisms on the shell-side of the palladium. However, the flow in the tubes is laminar, so the boundary layer mass transfer resistance for the diffusion of hydrogen to the palladium surface can be appreciable. Such a laminar boundary layer mass transfer resistance would be expected to be strongly dependent on the gas velocity within the tubes.

Data at 0.00018 m<sup>3</sup>/hr (3 cm<sup>3</sup>/min) per-tube hydrogen feed flow were regressed to correlate permeability for two ranges of the per-tube nitrogen feed flow rates (i.e., below and above 0.02 m<sup>3</sup>/hr). The correlations were then adjusted for all hydrogen flow rates.

### III. RESULTS

The modified Murav'ev model for countercurrent flows was applied to compute the low-pressure diffuser performance at various hydrogen feed flow rates. The calculated data cover a large range of feed flow rates. The comparison of the calculated hydrogen retentate composition (expressed in ppm) with test data is in Fig. 4. Overall, the modeling results are in agreement with experimental data. The agreement is less favorable at high hydrogen and nitrogen flow rates. However, the testing exhibited considerable experimental error in measured retentate partial pressures (therewith, hydrogen retentate composition) at high nitrogen flow rates which would have an adverse impact on data comparison.

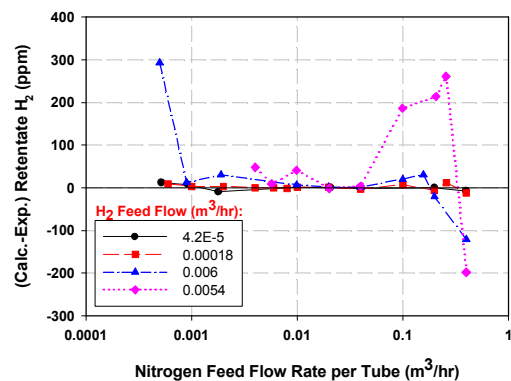

Fig. 4. Comparison of calculated hydrogen retentate composition with test data

### IV. CONCLUSIONS

A hydrogen permeator model developed by Murav'ev was successfully modified to adequately account for the flow configurations of a low-pressure diffuser. Correlations for permeability were provided for a large range of hydrogen and nitrogen feed flow rates. The diffuser performance data produced by the modified

model are in agreement with test data except at high feed flow rates when large experimental error would make any comparison difficult.

### NOMENCLATURE

d	Inner diameter of the tube
F	Inner surface area of the tube
L	Tube length
p	Pressure in the tube
p <sub>a</sub>	Hydrogen pressure at the open end of tube
p <sub>o</sub>	Pressure at normal condition
p <sub>p</sub>	Permeate pressure
p <sub>r</sub>	Retentate pressure
p <sub>v</sub>	Partial pressure of hydrogen in the gas mixture
p <sub>vo</sub>	Pressure of the gas feed
Q	Flow rate of hydrogen
Q <sub>o</sub>	Feed flow rate
Q <sub>p</sub>	Permeate flow rate
Q <sub>r</sub>	Retentate flow rate
Q <sub>v</sub>	Flow rate of gas mixture
T	Temperature
T <sub>o</sub>	Temperature at normal condition
u	Cross-section averaged flow velocity in the tube
X	Hydrogen mole fraction in the gas mixture
X <sub>r</sub>	Hydrogen mole fraction in the retentate
X <sub>v</sub>	Hydrogen mole fraction in feed
γ	Permeability
δ	Membrane thickness
λ	Flow resistant
μ	Dynamic viscosity
ρ	Gas density in the tube

### ACKNOWLEDGMENTS

The information in this paper was developed during work done under Contract No. DE-AC0996SR18500 with the U.S. Department of Energy.

### REFERENCES

1. L. L. Murav'ev, "Model for Calculating and Optimizing Gas Flow Rate in the Hydrogen-Permeable Capillaries of Permeators," *Theoretical Foundations of Chemical Engineering*, **36**, 3, 235 (2002).
2. T. Hang, M.B. Gorenssek and L.D. Koffman, "Modeling of the Savannah River Site High Level Waste Evaporator Systems," *Proceedings of the 2003 Advanced Simulation Technologies Conference (ASTC'03)*, Orlando, Florida, March 30 - April 3, 2003, p.71, The Society for Modeling and Simulation International.