

This document was prepared in conjunction with work accomplished under Contract No. DE-AC09-96SR18500 with the U. S. Department of Energy.

DISCLAIMER

This report was prepared as an account of work sponsored by an agency of the United States Government. Neither the United States Government nor any agency thereof, nor any of their employees, makes any warranty, express or implied, or assumes any legal liability or responsibility for the accuracy, completeness, or usefulness of any information, apparatus, product or process disclosed, or represents that its use would not infringe privately owned rights. Reference herein to any specific commercial product, process or service by trade name, trademark, manufacturer, or otherwise does not necessarily constitute or imply its endorsement, recommendation, or favoring by the United States Government or any agency thereof. The views and opinions of authors expressed herein do not necessarily state or reflect those of the United States Government or any agency thereof.

This report has been reproduced directly from the best available copy.

**Available for sale to the public, in paper, from: U.S. Department of Commerce, National Technical Information Service, 5285 Port Royal Road, Springfield, VA 22161,
phone: (800) 553-6847,
fax: (703) 605-6900
email: orders@ntis.fedworld.gov
online ordering: <http://www.ntis.gov/help/index.asp>**

**Available electronically at <http://www.osti.gov/bridge>
Available for a processing fee to U.S. Department of Energy and its contractors, in paper, from: U.S. Department of Energy, Office of Scientific and Technical Information, P.O. Box 62, Oak Ridge, TN 37831-0062,
phone: (865)576-8401,
fax: (865)576-5728
email: reports@adonis.osti.gov**

Applying Simple Technology Accomplishes Visual Inspection Challenges

Casandra W. Robinson
Westinghouse Savannah River Company, Building 773-A, D1110, Aiken SC 29808,
casandra.robinson@srs.gov

Abstract – This paper discusses the successful implementation of simple video technologies at the Savannah River Site (SRS) to perform complex visual inspection, monitoring, and surveillance tasks. The constraints and challenges associated with remote viewing are discussed, and examples of applications are given.

I. INTRODUCTION

The Savannah River Site (SRS) is a Department of Energy facility in South Carolina that has been in operation since the early 1950s. The original mission was the production of nuclear weapons materials. In recent years, the mission has changed to the management of the nuclear weapons stockpile, nuclear materials, and the environment. SRS is currently working towards accelerated cleanup of radioactive waste and closure of facilities that are no longer needed. The Savannah River Technology Center (SRTC) is the applied research and development laboratory for SRS and provides technical support and equipment development for site missions.

Work at SRS involves many radioactive, hazardous, and remote operations and activities, which require monitoring or surveillance. As well, many facilities, including tanks, cells, and pipelines, require inspections but are inaccessible to humans. SRTC supports SRS in these situations by applying simple remote viewing technologies to address these issues and accomplish monitoring and inspection goals.

II. BACKGROUND

SRS began production of nuclear materials for weapons in the 1950s. To support this mission, five reactors, two chemical separations plants, a heavy water extraction facility, a nuclear fuel and target fabrication facility, a tritium extraction facility, and waste management facilities were built. Irradiated materials were transferred from the reactors to the chemical separation plants, where the irradiated fuel and target assemblies were processed to separate useful materials from waste. After refinement, nuclear materials were shipped to other DOE sites for final application. [1] The high radiation rates and high levels of radioactive contamination associated with site operations require that

these operations be performed and monitored remotely to keep humans out of dangerous areas.

For many years, only radiation-hardened viewing components, cameras, and lenses were used at SRS. These components required long lead-time for procurement, were large and cumbersome, were extremely expensive, and had complex wiring requirements. As technology has improved, CCD and CMOS cameras and standard video camera lenses are now being used routinely instead of radiation-hardened components. These devices are readily available, small, inexpensive, easy to install, and very durable in harsh conditions. This, combined with advancements in the technology of related accessories, has made it possible to accomplish previously impossible remote viewing tasks.

III. OPERATING ENVIRONMENT DETAILS

For remote viewing applications, two factors play a major role in terms of whether the task can be accomplished or not and what components can be used: (1) space and access constraints and (2) environmental conditions of temperature, radiation levels, humidity, and other severe conditions.

Space and access constraints are given first consideration in determining the feasibility of performing a remote viewing task and selecting components. The size of video cameras, lenses, and other accessories has decreased dramatically in the last ten years. Many micro-cameras and lenses are readily available and inexpensive. One type used repeatedly at SRS with excellent results is the Supercircuits PC53XP camera, which is 1.63 cm³. A second type is a two-part assembly with a small camera head (7mm diameter x 42mm length) and a remote control unit connected by a 15m cable. If the size must be smaller, a videoscope, such as an Olympus model IV6, is

often used. This videoscope is 5mm diameter and up to 7.5 m in length.

Due to access constraints, locations requiring visual inspections or monitoring pose a challenge regarding transmission of video and control signals. These challenges result in cases where existing wiring must be used, entry must be through very small opening, or travel through complex piping is required. In addition to standard wiring methods, over-the-coax, twisted pair, phone line, and Ethernet transmission methods have been successfully implemented at SRS. Wireless transmission has also been successfully used but is not widely implemented due to security issues at SRS.

The “over-the-coax” control method simply superimposes the control signals onto the vertical blanking interval of the video signal so that they are not seen on the video monitor. Several types of systems have been used repeatedly at SRS, including Pelco Coaxitron[®], Vicon Vicoax[®], and FM Systems Alarm Superhighway.

Twisted pair and phone line transmission systems have been implemented as well. The Nitek TS515 system has been used with excellent results to transmit video and controls up to 1500 feet over unshielded twisted pair (UTP) wiring. Equipment is available to transmit up to 12,000 feet, but this has not been applied at SRS. The Kalatel RSM-1600 remote monitoring system has been used to transmit video and controls over phone lines from any location. The Axis 2400 Video Server has been used to monitor a process control room from a remotely located computer via an Ethernet network.

The environmental conditions must also be considered. Most of the temperatures encountered in SRS operations requiring remote viewing range from room temperature to 50 degrees C, but there are applications, such as viewing within furnaces, where temperatures reach 1100 degrees C. For those extreme cases, SRS has patented a protective housing to keep the video components within recommended limits. [2] Standard video components are generally rated to operate up to 40 degrees C; however, testing and operations at SRS have proven that CCD cameras can withstand temperatures up to 75 degrees C. A camera that was specifically tested was the Toshiba IK-SM45H. The camera functioned for several minutes at the high temperature before the image appeared to brown out. After cool-down, the camera functioned properly once again.

High radiation levels are typical in SRS operations, and standard components have been used in high radiation fields with excellent results. As the level of radiation increases, the video image begins to have “speckles”, and the amount of “speckles” increases with the radiation

level. In particular, the Microvideo MVC-2120WP-LED color camera has been successfully used in a radiation field varying from 0 to 13 Rads/hour with no visible degradation in the video image. Above 13 Rads/hour, some “speckles” appeared in the image, but the image quality remained excellent. When the camera was removed from the radiation field, the “speckles” disappeared. Genwac GW-902H cameras are used continuously in radiation fields, and continuous exposure causes pixel burnout over time that becomes evident in low light levels. A Toshiba IK-SM45H video camera was tested to determine its response to radiation exposure over time. The camera was dosed with 115,000 Rads over 24 hours. The result following exposure was that the video image grew somewhat darker, but the camera remained operational.

After taking into account space and access constraints and environmental conditions, the appropriate components can be selected from the myriad options available.

IV. EXAMPLES OF TYPICAL APPLICATIONS

The following applications are examples of simple video technology being used at SRS in areas of the chemical separations plants, stacks, gloveboxes, fuel storage basins, ductwork, and cells.

Each chemical separations plant building is an 835-foot long, multilevel facility and is referred to as a “canyon” because of its long, rectangular shape. Radioactive operations are performed inside two parallel smaller canyons, referred to as “Hot” and “Warm” canyons indicating the levels of radiation within them. The radiation rates inside portions of the canyon are lethal at a close distance. The Hot and Warm Canyons each house a series of cells with concrete walls and cell covers,



Figure 1: Standard CCD Camera and Lens Assembly

and all work is performed remotely from a central control room using bridge cranes. [3] Initially, an optical system similar to a periscope was used for remote viewing. Later, radiation-hardened systems, consisting of video cameras, zoom lenses, and pan-and-tilt devices, were installed on the crane, which improved the viewing capabilities of the operators by providing “bird’s eye” views of the canyon. Each crane has eight to ten video systems. Within the past 5 years, as radiation-hardened components failed, standard Genvac CCD cameras and Tokina zoom lenses were installed as replacements into the existing housings. This resulted in an estimated \$400,000 cost savings for the initial camera replacement. Figure 1 shows the current camera and lens assembly.

In addition to the overview cameras on the cranes, specialized systems are developed as needed to accomplish specific tasks within the canyons. All systems are designed to be operated from the existing camera/lens controls in the crane control room. An example is a video assembly designed to perform remote measuring task of a fuel insert in support of nuclear fuel processing (Figure 2). One of the operations performed in



Figure 2: Remote Measuring Tool

the canyon is the dissolution of Mark 16B fuel. The fuel is first placed into an “insert” to hold it and to ensure nuclear criticality safe spacing, and that is then placed into a dissolver filled with nitric acid solution. SRS possessed one qualified insert for this type of fuel, and Engineering realized that if an older, spare Mark XII fuel insert could be qualified, both inserts could be used and dissolve twice as much fuel. A team consisting of Engineering, Operations, and SRTC personnel developed a method to remotely measure the inside dimensions of the insert to qualify it for service. The 20-foot long Mark XII insert resembles a large egg crate with four rectangular quadrants, sized to hold bundles of fuel assemblies (Figure 3). The insert was placed horizontally on the floor, and using the crane, a small assembly containing a Supercircuits CMOS camera with lights and ruler were inserted through 24 1-inch holes in the insert to measure the inside widths of the four quadrants against values used for determining nuclear criticality limits for operation. Use of the remote measuring tool by the crane was necessary to avoid personnel radiation exposure. The bottom line was a savings of over \$1 million and 14

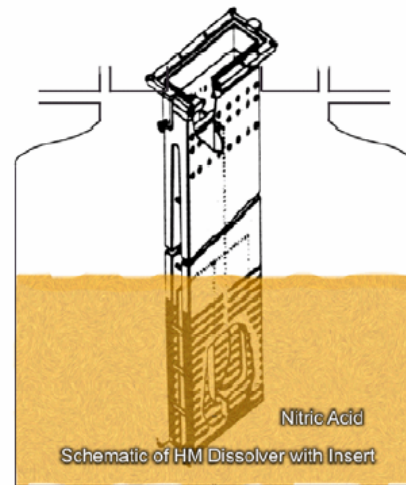

Figure 3: Dissolver with Mark XII Insert

months less time to process the fuel. [4]

A second type of specialized system for the canyons was developed to provide viewing around or beneath obstructions where the crane cameras couldn’t see. The assembly contains a Panasonic pan-tilt-zoom “dome” camera with built-in lights and stand-offs to allow the assembly to be placed on the canyon floor (Figure 4). The “over-the-coax” method of control and video signal transmission was used so that only power wires and a video cable are required. An interface box was designed to enable operation from the existing controls in the crane control room. The assembly is lowered into position by

the crane, and the cables are fed through coiled tubing around the crane hook for cable management purposes.

A third area of the canyons that must be viewed is vessel or tank interiors. Figure 5 shows a camera system



Figure 4: Pan-Tilt-Zoom Dome Camera Assembly



Figure 5: Tank Interior Inspection Assembly

developed for viewing inside tanks that contains a Microvideo MVC-2120-WP-LED waterproof camera assembly with built-in LED's. This assembly is hung from the crane hook and lowered down into cells or tanks.

Related to the canyons are the air exhaust stacks that release filtered canyon air into the atmosphere. Inside the stacks are isokinetic probes that sample the air leaving the stacks, and the internal surfaces of the probes must be inspected annually. The isokinetic probe, shown in Figure 6, has an ID of approximately 0.9 inches, and the tapered nozzles are 3 inches in length. A camera/LED assembly was fabricated to view the nozzles from within the probe (Figure 7).

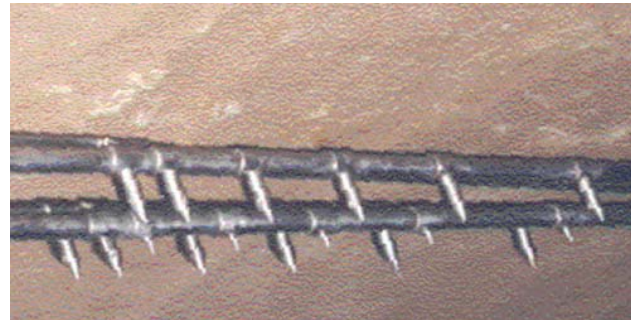

Figure 6: Isokinetic Probe Nozzles



Figure 7: Isokinetic Probe Internal Inspection Assembly

Some operations at SRS that involve high levels of radioactive contamination but low levels of radiation are performed within gloveboxes (Figure 8). One SRS facility where operations are performed within gloveboxes is HB-Line. HB-Line is a chemical processing facility that was built to support the production of Plutonium-238 (Pu-238), a power source for deep space exploration. The HB-Line processes are performed in thin, rectangular tanks within the gloveboxes, and routine inspections of these tanks are required to maintain normal operations. [5] Installation of equipment inside a glovebox is a challenge because the glovebox containment must be maintained. Figure 9 shows a camera assembly developed for use inside a glovebox. The assembly is made in two sections to allow for easy insertion into the glovebox through a gloveport. The



Figure 8: Typical Glovebox



Figure 9: Glovebox Camera Assembly

sections are assembled inside the glovebox, and the camera head is lowered into the tank.

One of the current missions of SRS is the safe receipt and interim storage of spent nuclear fuel (SNF) assemblies from SRS reactors and from domestic and foreign research reactors. These fuel assemblies are handled and stored underwater in large indoor basins to provide shielding to prevent personnel exposure to radiation. Routine inspections of all assemblies are required, and the identification numbers of newly received assemblies must be verified.[6] Because the assemblies are underwater, a waterproof pan-tilt-zoom video system supplied by RJ Electronics is used (Figure 10). The system is suspended from an overhead crane



Figure 10: Basin Inspection System

and is remotely controlled by an operator from a safe location. This system provides high-resolution, adjustable video images, and it has been used in many SRS applications.

V. CONCLUSION

As SRS continues working towards accelerated cleanup of radioactive waste and closure of facilities, many more challenges will arise requiring remote viewing, inspections, and monitoring. Improvements in remote viewing technologies combined with creative engineering will enable SRTC to continue support SRS in meeting these challenges.

ACKNOWLEDGMENTS

The author would like to acknowledge SRTC personnel who provide design and technical support in development of remote viewing systems: David Martinez and Bruce Blackmon.

REFERENCES

1. "Savannah River Site Fact Sheet," Available from Internet: <www.srs.gov/general/news/newpub-rel/factsheets/srs.pdf>.
2. Robinson, Casandra W., and Smith, Robert H., "Going Where No Man Can Go," Proceedings *from the American Nuclear Society 10th International Conference on Robotics and Remote Systems for Hazardous Environments*, Gainesville FL (March 28-31, 2004).
3. Nance, Thomas A., Boylston, Micah L., Robinson, Casandra W., Sexton, William C., Heckendorn, Frank M., "Apparatus for Observing a Hostile Environment," Patent # 6,111,599, Available from Internet: <patft.uspto.gov>.

4. Washburn, Tim, "Invention Will Save Time and Money for Mark 16B Campaign", *H-Completion News*, Volume 12, Issue 4, January 29, 2003.
5. "HB Line Fact Sheet," Available from Internet: www.srs.gov/general/news/newpub-rel/factsheets/hbl.pdf.
6. "Spent Nuclear Fuel Fact Sheet," Available from Internet: www.srs.gov/general/news/newpub-rel/factsheets/snf.pdf.